

6 Apply (3) 3/8" beads of roofing sealant around the opening.

- 1st bead set 1" out from opening
- 2nd bead set out 1" from 1st bead
- 3rd bead set out 1" from 2nd bead

7 Set the skylight over the opening with the 'THIS EDGE DOWN' label at the bottom of the opening. Fasten the skylight to the roof deck using only the screws provided. (#8 x 1" pan head screw). Every installation hole must be used.

Important: The bottom flange of the skylight must go on top of the shingles.

8 Place sealant on the head of each fastener and a large bead of sealant as shown.

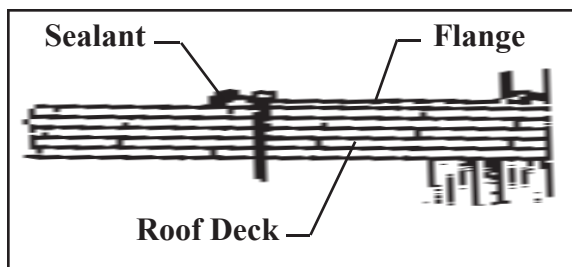

9 Now shingle up sides and across top. Place shingles, as far in as possible, but be careful not to nail through skylight flange.

EXTREME WEATHER/DURA SKYLIGHT LIMITED WARRANTY

Sun-Tek Manufacturing, Inc. ("Sun Tek") 10303 General Drive, Orlando, Florida 32824, (407) 859-2117, warrants this Skylight on the following terms and conditions: **A. Warranty Coverage:** This warranty applies to both the original purchaser and first consumer-owner of a Skylight made by Sun-Tek. **B. Warranty Duration:** This warranty shall remain in effect for a period of five (5) years on Model SF and ten (10) years on all other Dura-Series models after the date the Skylight is purchased or the date the skylight is delivered to the first consumer-owner, whichever is later. One (1) year on electric components.

C. Warranty Application: This warranty applies only to the materials and fabrication of the Skylight and does not apply to any defect or damage caused by improper use, improper installation, improper care, shipping damage or accident. This warranty does not cover any cosmetic changes in skylight, including but not limited to pitting, hazing, paint finish, discoloration.

D. Performance by Sun-Tek: During the warranty period, Sun-Tek will provide free of charge an equivalent new skylight (or component thereof) for one found to be defective in material or workmanship. Shipping costs of such replacements are not the responsibility of Sun-Tek. Sun-Tek will not be responsible for any costs of removal or re-installation.

E. Validation Procedure: To obtain performance under this warranty, the purchaser must: (1) **On installed skylights, contact Sun-Tek for instructions before removing skylight. Removal of skylight from roof before inspection will void warranty.** (2) Notify Sun-Tek in writing of any claim within thirty (30) days after the defect is discovered; (3) Sun-Tek or its authorized agents must examine the skylight and determine to its satisfaction whether the defect is covered by this warranty; and (4) Present a copy of the receipt as proof of purchase.

F. Implied Warranties: IMPLIED WARRANTIES, INCLUDING BUT NOT LIMITED TO IMPLIED WARRANTIES OF MERCHANTABILITY AND FITNESS FOR A PARTICULAR PURPOSE, SHALL NOT EXTEND BEYOND THE DURATION OF THE EXPRESS WARRANTIES PROVIDED HEREIN. Some states do not allow limitations on how long an implied warranty lasts, so the above limitation may not apply to you. **G. Incidental or Consequential Damages:** SUN-TEK SHALL NOT BE LIABLE FOR ANY INCIDENTAL OR CONSEQUENTIAL DAMAGES WHATSOEVER, INCLUDING BUT NOT LIMITED TO LOSS OF TIME OR REVENUE, DAMAGE RESULTING TO OTHER PROPERTY OR OTHER EXPENSES. Some states do not allow the exclusion or limitation of incidental or consequential damages, so the above limitation or exclusion may not apply to you.

H. Exclusive Warranty: THIS WARRANTY IS EXCLUSIVE AND IN LIEU OF ALL OTHER WARRANTIES. This warranty gives you specific legal rights. You may have other rights which vary from state to state.





Sun-Tek Manufacturing, Inc.
 10303 General Drive
 Orlando, FL 32824
 407 / 859-2117
 www.sun-tek.com
 customerservice@sun-tek.com

MODEL HSF

Extreme Weather Series

INSTALLATION INSTRUCTIONS

STS 1000

3 rings of sealant beneath flange (continuous) around perimeter of flange (continuous) and on top of each flange screw

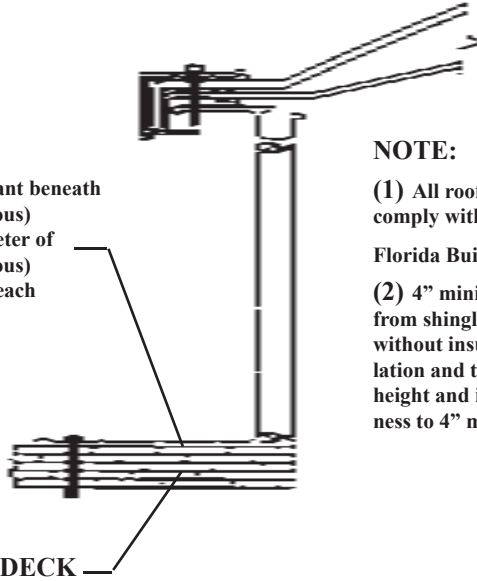

NOTE:

- (1) All roofing details shall comply with chapter 15 of the Florida Building Code
- (2) 4" minimum distance from shingle, or B. U. R. without insulation. For insulation and tile roof add tile height and insulation thickness to 4" minimum height.

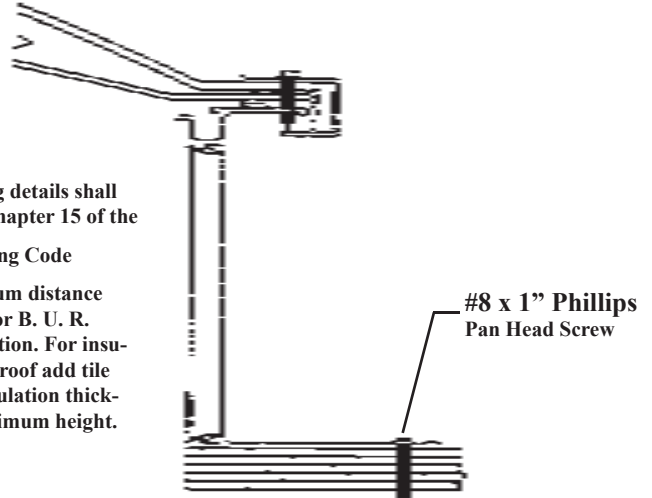

#8 x 1" Phillips Pan Head Screw

ROOF DECK



FAILURE TO FOLLOW RECOMMENDED INSTALLATION PROCEDURES MAY VOID WARRANTY

1 Cut rough opening:

To properly position skylight between trusses/rafters, locate the roof opening from the underside of the decking. Drill holes or drive nails to mark corners. (If this area is not accessible, locate the ceiling joists from inside the house, mark and cut opening in ceiling, then mark roof opening.)

2 Before cutting roof opening, check measurements against size chart. Snap a chalkline from corner to corner, or draw line with a straightedge, then cut roof opening.

3 Remove shingles 6 - 8" out from roof opening.

4 Frame the roof opening:
 Cut 2 x 4's to fit between trusses at the top and bottom of the opening. Nail into place. Rough opening must be framed under the roof deck.

5 Shingle up to the bottom of the roof opening.

SIZE CHART

Size Code	Roof Opening
1430	14-1/2" x 30-1/2"
1446	14-1/2" X 46-1/2"
2222	22-1/2" X 22-1/2"
2230	22-1/2" x 30-1/2"
2236	22-1/2" x 36-1/2"
2246	22-1/2" x 46-1/2"
3046	30-1/2" x 46-1/2"
3636	36-1/2" x 36-1/2"
4646	46-1/2" x 46-1/2"

You will need:

- hammer
- keyhole saw
- skill saw
- nails
- drill
- 2 x 4's
- sealant/mastic
- tape measure
- chalkline or straight edge
- trowel or caulk gun
- utility knife

RECOMMENDED SEALANTS:

- Non-hardening roof cement
- Butyl rubber sealant/caulk
- STS 1000